

# THE HIGH-PERFORMANCE CONE CRUSHER ON CRAWLER WITH 2 TIMES LARGER CRUSHING CAPACITY THAN CONVENTIONAL CONES

## CONE CRUSHER WITH THE WORLD-LOWEST MACHINE HEIGHT

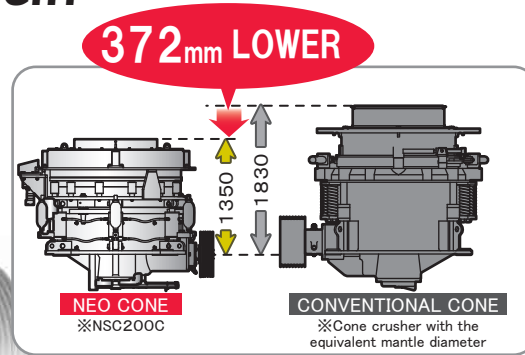
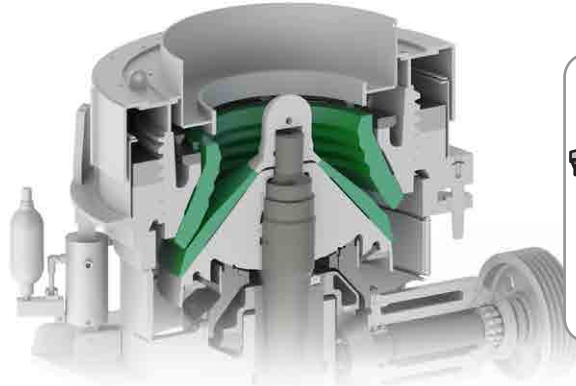

## CHOICE OF POWER SOURCE - DIESEL GENERATOR OR COMMERCIAL POWER

In case the consumption of commercial power source is limited or costly depending on the time of power consumption, the machine can be driven by the diesel generator.

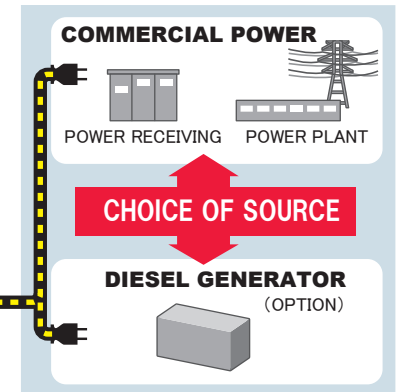

### 1 HIGHER CRUSHING PERFORMANCE

Optimum crushing geometry and movement give outstanding crushing effects with twice as large capacity as the conventional cones in a compact machine size.

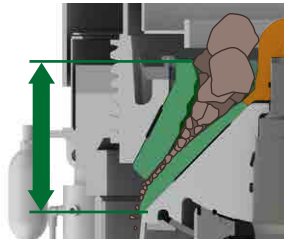

### 2 EASY SETTING ADJUSTMENT

Hydraulic driven ring gear rotates the concave for the desired setting with finger-tip control at the control panel.



### 3 INSTANT TRAMP IRON RELEASE

Hydraulic cylinders with N2 accumulators give easier passage of the tramp iron. In case of jamming, quick recovery is possible with the finger-tip control at the control panel.



## EXTERNAL DIMENSIONS

NE200C

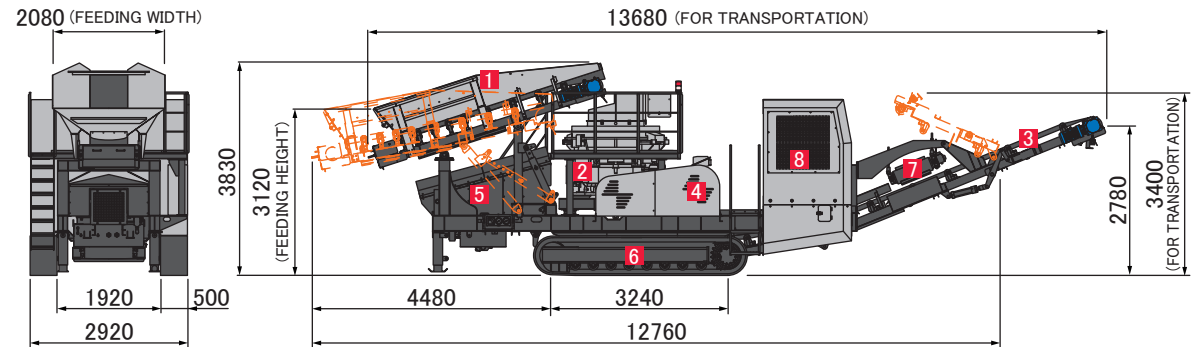

## NAMES OF COMPONENTS

- ① FEED CONVEYOR ② CONE CRUSHER ③ BELT CONVEYOR ④ HYDRAULIC UNIT ⑤ LUBRICATION UNIT  
⑥ CRAWLER ⑦ MAGNETIC SEPARATOR (Option) ⑧ DIESEL GENERATOR (Option)

## SPECIFICATIONS

MODEL	CONE CRUSHER		APPROX. CAPACITY (TPH)	APPROX. WEIGHT (TON)		DRIVE SYSTEM		
	MODEL	MAX. FEED SIZE T×W×L (mm)		POWER (kW)	DIESEL GENERATOR WITH	DIESEL GENERATOR WITHOUT	CRUSHING	TRAVEL
NE200C	NSC200	90×130×180	110~150	110~200	38	35.5	ELECTRIC	HYDRAULIC
NE300C	NSC300	100×140×200	190~220	190~300	-	42		

■ Processing capacity depends on the quality of raw materials, grain size and input mass.  
■ This machine specifications and dimensions are subject to change without prior notice.

**Safety Precautions:** (Note) Please refrain from using reprint of drawings and matters that are described in this document, without prior notice to our Company. In order to use this product correctly and safely, please read the technical Manual carefully before use.

# Dendoman NE-C CONE Series

NEW HYBRID CRAWLER-MOUNTED  
**CONE CRUSHER** FOR HIGHER PRODUCTIVITY  
AND EASIER MAINTENANCE  
For crushing rocks in quarries, for recycling demolition concrete



## THE ADVENT OF “Dendoman”

Nakayama has chosen and developed a new type of crawler-mounted cone crusher with the electric-driven crushing mechanism and hydraulic travelling and release system to minimise the overall life-cycle costs of the machine including fuel and running costs as well as initial purchase cost.

This “**Dendoman**” gives higher energy efficiency, easier maintenance and troubleshooting with electric system.

DENDO-means “Electric-powered” in Japanese, and “**Dendoman**” is the name of Nakayama electric-driven crawler-mounted equipment.

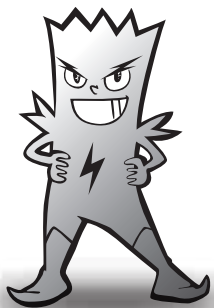

**NAKAYAMA IRON WORKS, LTD.**